

规格承认书

Specification for approval

产品名称: **BFLP 低背汽车插片保险丝 58V**

**Product Type: Low Back Profile Micro Auto Car Mini
Blade Fuse 30A 58V Green For Infiniti Subaru Acura Mazda
Automotive**

Ao littel Technology Co.Ltd.

Bld. 16,Yanhe East Road,Xiangdong Village, Dongguan 523833,
Guangdong,China

H.P.: 1371362419

QQ #: 3217998702

<http://www.passivemall.com/>

Fax #:0769-89390418

Email : eric.lye@aolittel.com

<http://www.aolittel.com/>

1. Scope

BFLP is a lower-cost and more compact BFMN

2. General Specifications

Rated Voltage: DC58V and less

Breaking Capacity: 1000A

Operation Temperature: -40°C - 80°C

Standard Packaging :20,000

Standard: ISO8820-9

3. Time-Current Characteristics

% of Ampere Rating(A)	Operating Time	
	MIN	MAX
110%	100 hrs.	-
135%	0.75 sec.	600 sec.
160%	0.25 sec.	50 sec.
200%	0.15 sec.	5 sec.
350%	0.04 sec.	0.5 sec.
600%	0.02 sec.	0.1 sec.

※The fuse characteristic may change depending on the conditions of use.

4. Electrical Performances

Ampere Rating(A)	Part Number	Housing Colors	Resistance Value	Voltage Drop
2A	1190	Gray	46.6 mΩ	126 mV
3A	1191	Violet	33.7 mΩ	137 mV
4A	1192	Pink	20.6 mΩ	109 mV
5A	1193	Tan	16.5 mΩ	115 mV
7.5A	1194	Brown	10.2 mΩ	105 mV
10A	1195	Red	7.38 mΩ	104 mV
15A	1196	Blue	4.55 mΩ	97 mV
20A	1197	Yellow	3.25 mΩ	94 mV
25A	1198	White(natural)	2.50 mΩ	93 mV
30A	1199	Green	1.94 mΩ	88 mV

※The fuse characteristic may change depending on the conditions of use.

5. Dimension (mm)

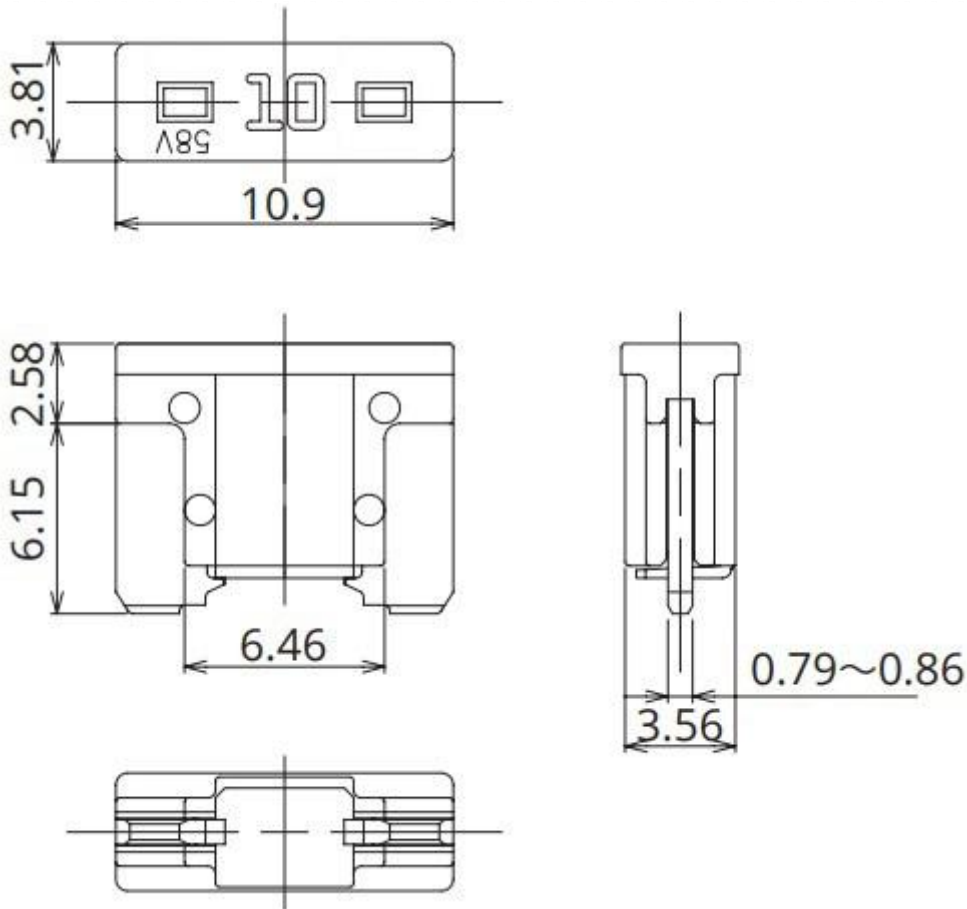

6. Time-Current Characteristics Chart

